



NEEDLES FOR SCHIFFLI-EMBROIDERY PERFECT EMBROIDERY ON BIG-BAR EMBROIDERY MACHINES



The production of lace is traced back over centuries.

The tool to produce good embroidery is and always has been "the needle." With developments of Schiffli embroidery machines (big-bar embroidery machines), demands on the needle have changed tremendously.

Only a perfect precision tool is able to produce the expectations of today's embroidery markets. Countless varieties of material, embroidery threads, and yarns exist. Embroidery machine speed capabilities are increasing constantly.

The Groz-Beckert needles meet these expectations with the lowest production tolerance standards. Mechanical properties and features that are consistent and not least of all, a smooth and wear resistant surface.

IDENTIFICATION OF THE NEEDLE FEATURES

Needle point and Needle size

In practice needles are frequently changed. A better-suited needle may be needed whenever new materials are to be embroidered or new embroidery threads are chosen. In order to avoid confusion, in the event that these needles may be used again, Groz-Beckert needles are color coded for size and point style.



The color schedule is as follows:

Schiffli-Nadeln				
Needle-size Nm	No.	RS-Point (Standard) no color coding	FG-Point = red	TR-Point = yellow
70	00			
80	0			
90	1			
100	2			
110	3			
130	4			
140	5			

THE POINT STYLES

The following point styles are available in our standard product range

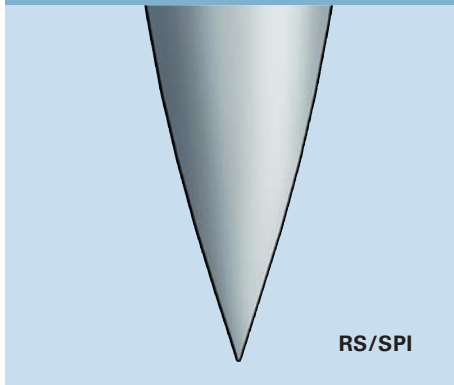

The standard point **RS** is suitable for most embroidery materials. Specifically where precise penetration and embroidery definition are features. Curtain and lace embroidery are examples.

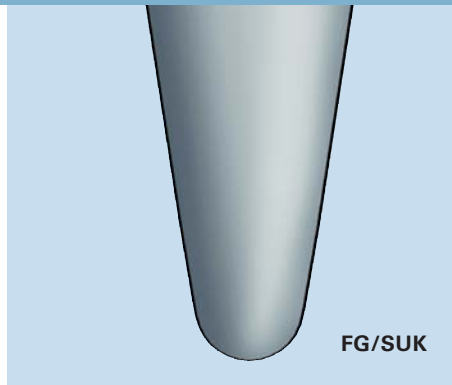

The medium ball point **FG** is a versatile point style, yet is especially suited to knit materials.

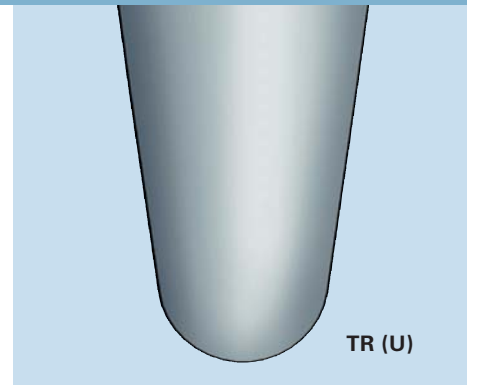

The wide ball point **TR** is most suitable for broad structured materials like tulle.

Standard needle eye or SA-needle-eye

The standard eyes on all Groz-Beckert Schifflli embroidery needles are designed for common embroidery threads.

When using coarse embroidery yarns or ornamental embroidery threads that are especially thick, the use of a needle with a bigger (SA) needle eye provides advantages. Both needle eye types are produced by Groz-Beckert.



Threading aid

Time is money. Certainly a valid statement for the threading of embroidery yarns through the needle. To do this as easily and quickly as possible Groz-Beckert offers special threading hooks.

When setting up the machine, or after a thread break, downtime can be reduced significantly.

The threading hooks can be purchased in two designs, and are available with or without a handle.

1. EI 46. 110 G1, 2. EI 47. 78 G1 and
3. EI P/2 65. 80 G1



EI 46. 110 G1 FOR NEEDLE SIZE \geq NM 110/3



EI 47. 78 G1 FOR NEEDLE SIZE \leq NM 100



EI P/2 65. 80 G1 FOR NEEDLE SIZE \leq NM 100

PROGRAM SCHIFFLI-EMBROIDERY NEEDLES: (WILL BE EXTENDED WHEN REQUIRED)

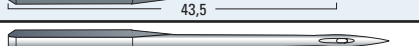
System	Point	Needle size Nm	Length butt to eye in mm	shank (∅) mm	Needle Threading
L83TOP / L83	RS	80, 90, 100, 110, 130	 47,5	1,60	
L83TOP / L83	TR	70, 80, 90, 100, 110	 47,5	1,60	
MD 83TOP KK	RS	100	 47,5	1,60	
L83TOP / L83	FG	80, 90, 100, 110	 47,5	1,60	
L83TOP SA	RS	90, 100, 110	 47,5	1,60	
L83TOP SA	TR	80, 90, 100	 47,5	1,60	
0110 / SM x 854 B	RS	80, 90	 43,5	2,00	
110 S / SH x 3	RS	70, 80, 90, 100, 110, 130	 43,5	1,60	
110 S / SH x 3	FG	70, 80, 90, 100, 110	 43,5	1,60	
110 S / SH x 3	TR	90, 100	 43,5	1,60	
110 SA	RS	90, 100, 110	 43,5	1,60	
110 SA	FG	90	 43,5	1,60	
110 SA TOP	TR	100, 110	 47,5	1,60	
110 STOP	RS	70, 80, 90, 100, 110, 130	 47,5	1,60	
110 STOP	FFG	100	 47,5	1,60	
110 STOP	FG	70, 80, 90, 100, 110	 47,5	1,60	
110 STOP	TR	70, 80, 90, 100, 110	 47,5	1,60	
110 SA TOP	FG	70, 80, 90, 100, 110	 47,5	1,60	
110 SA TOP	TR	70, 80, 90, 100, 110	 47,5	1,60	
0854	RS	90, 100, 110, 130	 43,5	2,00	
0854 / SM x 854	TR	80, 90, 100, 110	 43,5	2,00	
0854 / 0854 V	FG	80, 90, 100	 43,5	2,00	
854 S / SH x 1	RS	70, 80, 90, 100, 110, 130	 43,5	1,40	
854 S / SH x 1	FG	80, 90, 100, 110	 43,5	1,40	
854 STR / SH x 1Y	TR	70, 80, 90, 100, 110, 130	 43,5	1,40	
854 SA	RS	100, 110	 43,5	1,40	
SH x 1KK	RS	90, 100, 110	 43,5	1,40	
SH x 1KK	FG	90	 43,5	1,40	
SH x 1KK	TR	80, 90, 100, 110	 43,5	1,40	
SH-C 25	RS	90, 100, 110	 43,5	1,40	
SH-C 25 KK	RS	110	 43,5	1,40	
SH-C 25	TR	100, 110	 43,5	1,40	
SH-C 43	TR	100	 43,5	1,40	

GROZ-BECKERT KG

PO Box 10 02 49

72423 Albstadt, Germany

Phone +49 7431 10-0

Fax +49 7431 10-3200/2777

s-vn@groz-beckert.com

www.groz-beckert.com

 **Needle threading left to right**
System Plauen

 **Needle threading right to left**
System Saurer