



Reduced maintenance effort

The versatile steel composite needle for the ideal combination of high performance and low maintenance

GROZ-BECKERT®

Groz-Beckert KG

Parkweg 2, 72458 Albstadt, Germany

Phone +49 7431 10-0, Fax +49 7431 10-2777

contact-knitting@groz-beckert.com

www.groz-beckert.com

Application

When spun fibers are used in high performance machines a lot of fly is generated that mixes with oil and metal particles which accumulate in the needle cut outs and needle tracks. The solution is the patented steel composite high performance needle by Groz-Beckert.

Profitability/productivity

Reduced needle consumption and longer maintenance intervals due to minimal fiber and oil deposits. Increased performance capability due to reduced needle weight and optimum vibration dampening of the needle shank.

Properties

This needle has a double low profile shank and, therefore, provides ideal cushioning characteristics for high speed operation. The cut-outs of the needle are filled with a special synthetic material to prevent the accumulation of dirt.

Quality

Uniform loops and flawless fabric quality, preventing lines in the fabric by reducing fiber deposits in the needle track to a minimum.

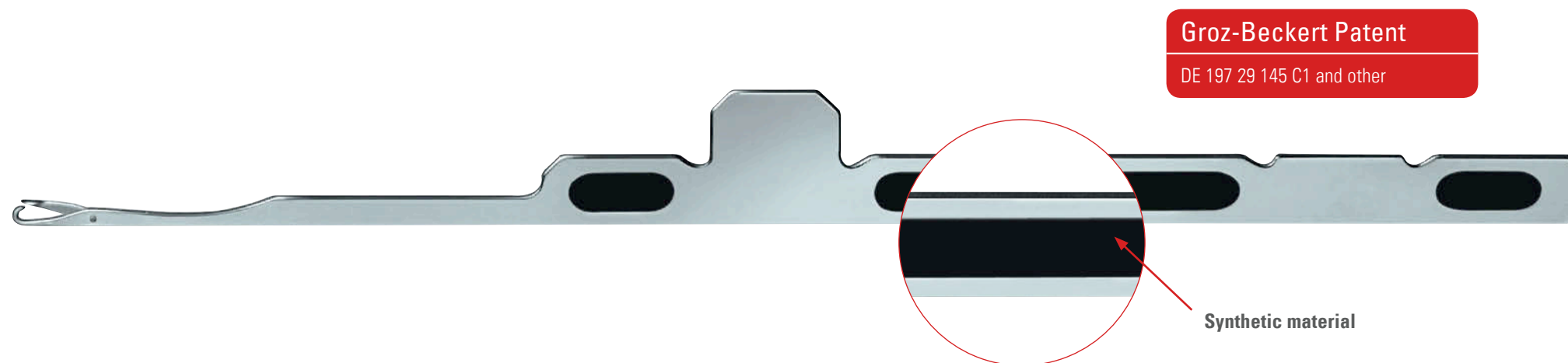

Comparison of the steel composite needle to the low-maintenance full shank needle and the high performance meander low profile needle:



Steel composite high performance needle

Combination of high performance and low maintenance.



Meander low profile needle

Used in state-of-the-art high performance machines.



Full shank needle

Used in machines of lower speeds.



User instruction

The compatibility of the cleaning oil with the steel component high performance needle should be checked with Groz-Beckert before use to prevent damage to the synthetic material.

Service

- Global sales network for fast delivery and reduced warehousing costs
- Research and development – development partnership from prototype to market introduction
- Process optimization by laboratory services
- Technical knowledge and improved quality comprehension with training offered by the Groz-Beckert Academy
- Further information under www.groz-beckert.com and in the “myGrozBeckert” app

